

N^o 15,670



A.D. 1910

Date of Application, 29th June, 1910

Complete Specification Left, 29th Dec., 1910—Accepted, 13th Apr., 1911

PROVISIONAL SPECIFICATION.

Improvements in Fishing Winches.

I, CHARLES FITZROY FARLOW, of 10, Charles Street, St. James' Square, London, S.W., Fishing Tackle Manufacturer, do hereby declare the nature of this invention to be as follows:—

5 The invention relates to fishing winches and consists of an automatic braking device of an extremely simple nature.

Various braking devices have been suggested and used for the purpose of checking the speed at which a fishing line runs out when a cast is made and preventing overrunning of the bobbin and consequent entanglement of the line. Many of these devices are of a more or less complicated nature and have to be
10 adjusted or used with a considerable amount of care.

The object of my invention is to provide a braking device which will automatically exert a drag on the bobbin of the winch proportional to its *vis inertiae* and thus prevent overrunning of the bobbin and consequent entanglement of the line.

15 According to the invention the above described object is effected by the use of a fly or fan which is located in a housing or casing forming part of the frame of the winch and communicating with the air by means of suitable holes or perforations. The fly or fan is operatively connected to the bobbin of the winch in any suitable manner. For instance, the fly or fan could be mounted on the
20 end of the bobbin shaft, or its blades can be attached to or form part of either flange of the bobbin, or it can be mounted on a shaft driven from the bobbin or the bobbin shaft in any suitable manner. The fly or fan may, if desired, be constructed in such manner that the angle of its blades can be adjusted or varied, or the blades may be so constructed, for instance by being loosely
25 mounted on radially disposed arms, that they will as the speed of rotation increases approach nearer and nearer to the inner surface of the housing or casing containing the fan. Further the fly or fan can be rotated at a speed greater than the bobbin or its shaft by interposed gearing, and the construction of the parts of the winch be varied according to the particular circumstances
30 of each case:

Dated this 29th day of June, 1910.

C. F. ENNIS,
Registered Patent Agent,
Jessel Chambers, 88, Chancery Lane, London, W.C.,
For the Applicant.

COMPLETE SPECIFICATION.

Improvements in Fishing Winches.

I, CHARLES FITZROY FARLOW, of 10, Charles Street, St. James' Square, London, S.W., Fishing Tackle Manufacturer, do hereby declare the nature of this inven-
[Price 8d.]



Farlow's Improvements in Fishing Winches.

tion and in what manner the same is to be performed to be particularly described and ascertained in and by the following statement:—

The invention relates to fishing winches and consists of an automatic braking device of an extremely simple nature.

Various braking devices have been suggested and used for the purpose of 5 preventing overrunning of the bobbin and consequent entanglement of the line. Many of these devices are of a more or less complicated nature and have to be adjusted or used with a considerable amount of care.

The object of my invention is to provide a braking device which will automatically exert a drag on the bobbin of the winch proportional to its *vis inertiae* 10 and thus prevent overrunning of the bobbin and consequent entanglement of the line.

According to the invention the above described object is effected by the use of a fly or fan which may be located in a housing or casing forming part of the frame of the winch and communicating with the air by means of suitable holes or 15 perforations. The fly or fan is operatively connected to the bobbin of the winch in any suitable manner. For instance, the fly or fan could be mounted on the end of the bobbin shaft, or its blades can be attached to or form part of either flange of the bobbin, or it can be mounted on a shaft driven from the bobbin or the bobbin shaft in any suitable manner. The fly or fan may, if desired, 20 be constructed in such manner that the angle of its blades can be adjusted or varied, or the blades may be so constructed, for instance by being loosely mounted on radially disposed arms, that they will, as the speed of rotation increases, approach nearer and nearer to the inner surface of the housing or casing containing the fan. Further the fly or fan can be rotated at a speed 25 greater than the bobbin or its shaft by interposed gearing, and the construction of the parts of the winch be varied according to the particular circumstances of each case.

In the case of large winches a number of fans or flies, adapted to be simultaneously rotated, might be used, or a fan consisting of a suitable number of 30 blades secured to the interior of the barrel of the bobbin might be used.

In order that my invention may be thoroughly understood I will now refer to the accompanying drawings which illustrate, by way of example, different constructions which may be adopted.

Figs. 1 and 2 are views of a winch provided with one construction of the 35 improved brake, Fig. 1 being a side elevation of said winch with the cover plate of the fan housing or casing swung aside, and Fig. 2 an elevation, partly in section, of the winch as it would appear when viewed at right angles to Fig. 1. Fig. 3 is a side elevation corresponding to Fig. 1, partly in section and illustrating a slightly modified construction of winch. Figs. 4 and 5 are views, 40 the latter partly in section, of a further modification. Figs. 6 to 9 are views, hereinafter particularly referred to, illustrating other constructions of the improved winch.

In all the figures 1 is the winch frame, 2 is the bobbin of the winch, 3 is the bobbin shaft, 4 is the winding handle or handle plate, as the case may be, and 45 5 is the scoop plate.

Referring first to Figs. 1 and 2 it will be seen that the improved automatic brake may consist of a fan formed of a pair of oppositely disposed blades 6 mounted on the end of the bobbin shaft 3 and rotating in a housing or casing 7 forming part of the winch frame 1. A suitable number of openings are provided by means of which a limited amount of air can enter and leave the housing 50 or casing 7. These holes 8 are preferably formed in a cover plate 9 which is hinged to the housing or casing 7 and is secured in position thereon in such manner as to be readily swung aside. The boss of the blades 6 is made of such size that it will fit somewhat tightly on to the end of the bobbin shaft 3, so that 55 the user of a winch can, if he so desires, readily remove the fan.

Farlow's Improvements in Fishing Winches.

If desired the blades of the fan, instead of being fixedly disposed parallel to the axis of the bobbin shaft, as shown in Figs. 1 and 2, may, as shown in Fig. 3, be mounted in a boss 10 in such manner that the angle of the blades 6 can be adjusted or varied. Again, as shown in Figs. 4 and 5, the blades 6 may be
 5 slidably mounted on arms 11, so that they will as the speed of the fan increases approach, in opposition to the action of springs 12, nearer and nearer to the inner surface of the housing or casing 7. The fan blades 6 may, as shown in Fig. 6, be attached to or form part of one of the flanges or side cheeks of the bobbin, or could in the case of large winches be secured to the interior of the
 10 barrel of the bobbin, as shown in Figs. 7 and 8.

In the case of large winches a number of fans 6, adapted to be simultaneously rotated, may be used. In this case, as shown in Fig. 9, the simultaneous rotation of the fans may be effected by means of a toothed wheel 13 secured to the bobbin shaft 3 and engaging with pinions 14 fixed to the bosses of the fans 6.

15 If desired any suitable means may be employed for adjusting the areas of the openings available for the admission of air to and its escape from the housing, casing or chamber containing the fan or fans. An example of such means is shown in Fig. 3, where 15 is a plate rotatably mounted on the cover plate 9 and provided with holes 16 corresponding to those in the cover plate.

20 Having now particularly described and ascertained the nature of my said invention and in what manner the same is to be performed, I declare that what I claim is:—

1. A braking device for a fishing winch adapted to automatically exert on the bobbin of the winch a drag proportional to the *vis inertiae* of said bobbin,
 25 substantially as described herein.

2. An automatic brake for a fishing winch consisting of one or more fans or flies connected to the bobbin of the winch and rotating within an enclosed space communicating by means of suitable holes with the air, substantially as described herein.

30 3. An automatic brake for a fishing winch consisting of a fan or fly mounted on one end of the bobbin shaft and contained within a housing or casing which forms part of the winch frame and communicates by means of holes with the air, substantially as described herein and illustrated by Figs. 1 and 2, Fig. 3, and Figs. 4 and 5 of the accompanying drawings.

35 4. An automatic brake for a fishing winch consisting of fan blades secured to the bobbin of the winch, substantially as described herein and illustrated by Figs. 6, 7 and 8.

40 5. An automatic brake for a fishing winch consisting of a plurality of fans or flies connected to the bobbin of the winch and rotating within a housing or casing which forms part of the winch frame and communicates by means of holes with the air, substantially as described herein and illustrated by Fig. 9 of the accompanying drawings.

Dated this 28th day of December, 1910.

45 C. F. ENNIS,
 Registered Patent Agent,
 Jessel Chambers, 88, Chancery Lane, London, W.C.,
 For the Applicant.

[This Drawing is a reproduction of the Original on a reduced scale.]

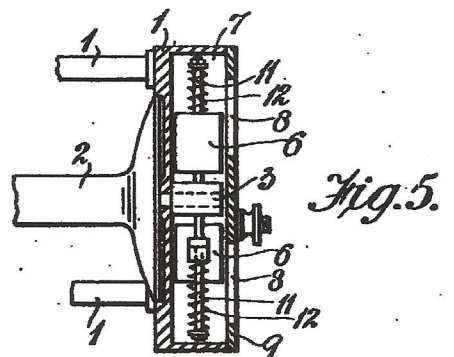
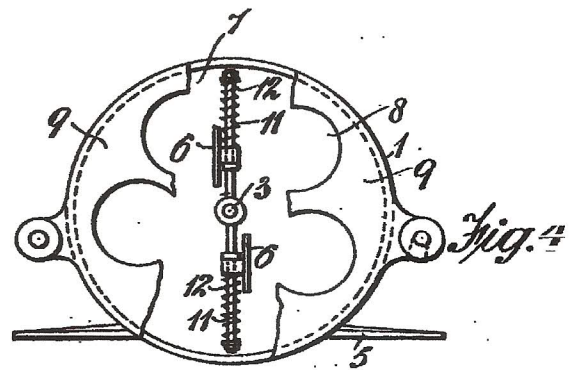
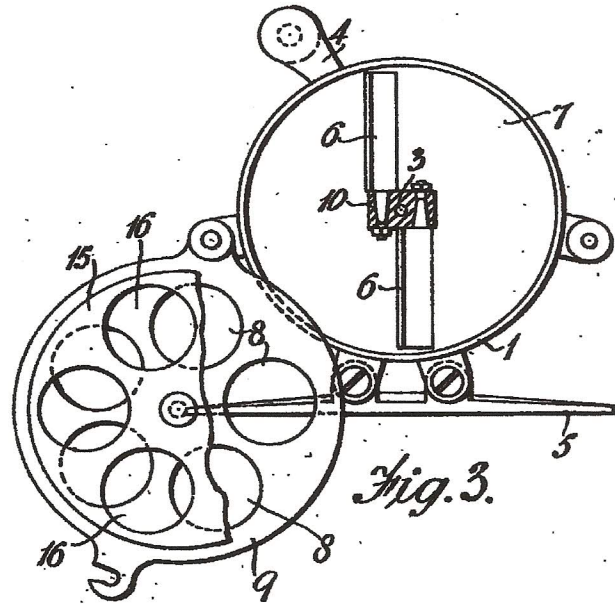
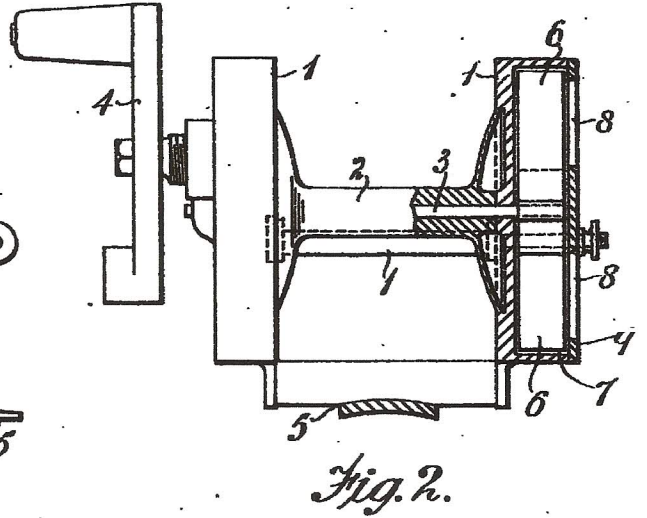
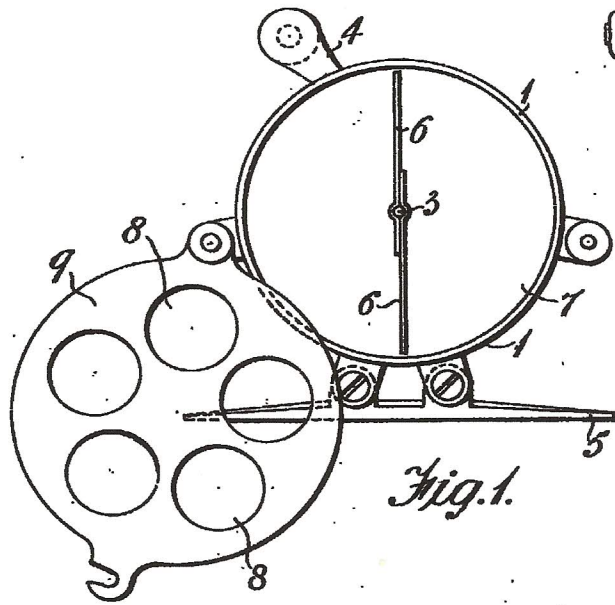

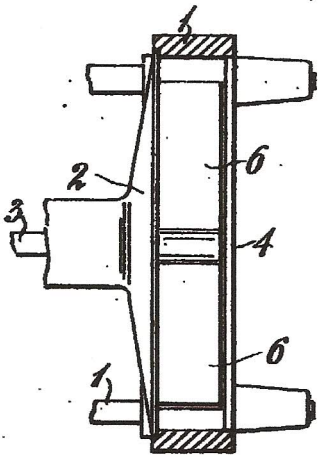

Fig. 6.

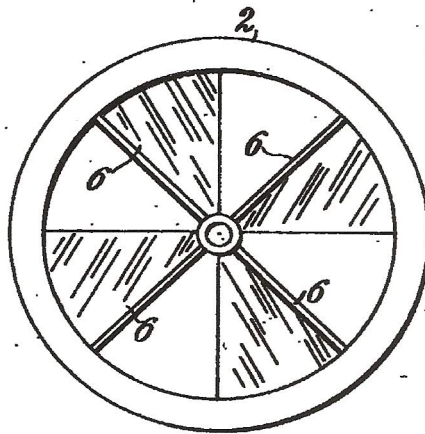

Fig. 7.

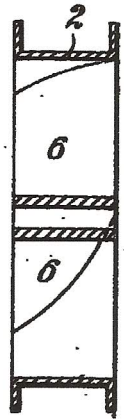

Fig. 8.

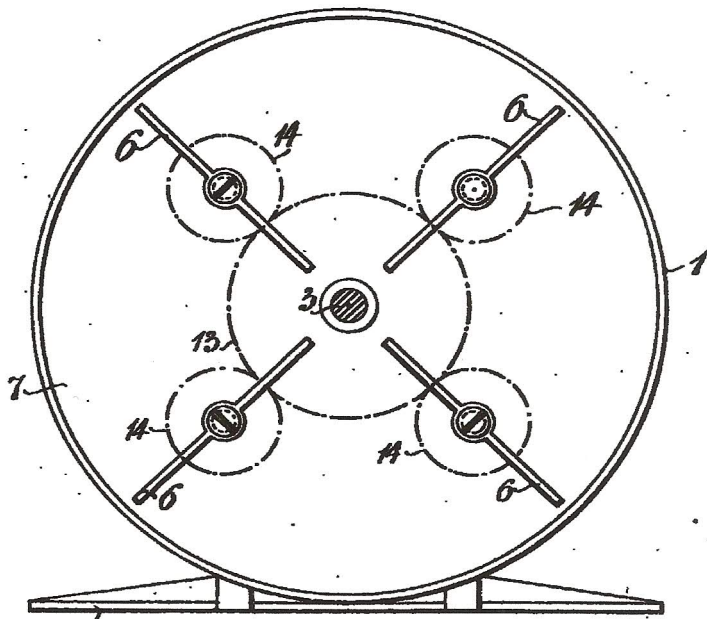

Fig. 9.

